

**Uni-directional ESD Protection Diode****Peak Pulse Power - 60 Watts**
Reverse Working Voltage - 5.0V**Description**

The H04D645V0L is low capacitance ESD arrays designed to protect high speed data interfaces. This series has been specifically designed to protect sensitive components which are connected to highspeed data and transmission lines from overvoltage caused by ESD(electrostatic discharge).

Features



- Protects up to four high-speed I/O lines & one power line
- Peak Pulse Power :Ppp = 60W (tp=8/20 us)
- Reverse Working Voltage : 5V
- Low capacitance: 0.6pF .max (Any I/O pin to ground)
- Low Clamping Voltage
- IEC 61000-4-2 (ESD) :±20kV(Contact) / ±30kV(Air)

Applications

- USB2.0 Power and Data lines protection
- Digital Visual Interface (DVI)
- High Definition Multi-Media Interface (HDMI)
- Display Ports
- MDDI Ports

Mechanical Data

- Case: SOT363 Package
- Case Material: "Green" Molding Compound UL Flammability Classification Rating 94V-0
- Terminals:Matte tin plated,solderable per MIL-STD-750,method 2026
- Component in accordance to RoHS
- Halogen Free

Note: Products with logo  or  are made by HY Electronic (Cayman) Limited.

Ordering Information

- Package :SOT363
- Reel Size :7 (inches)
- Quantity Per Reel :3,000/Tape & Reel
- Quantity One Box :45,000/Tape & Reel
- Quantity One Carton :180,000/Tape & Reel

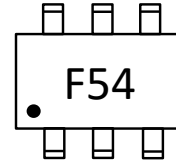
Marking Information

" F54 " = Product Type Marking Code

Package Outline

SOT363 Top View

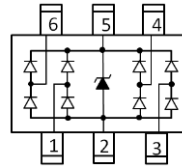
Device Schematic & PIN Configuration

Pin Assignment	
1, 3, 4, 6	Input lines
5	Vcc
2	Ground

Maximum Ratings (@TA = +25°C, unless otherwise specified.)**Absolute Ratings**

Parameter	Symbol	Value	Unit
Peak Pulse Power Dissipation (8/20 us)	P _{PP}	60	W
Peak Pulse Current (8/20 us)	I _{PP}	4	A
ESD Protection- Contact (Standard IEC 61000-4-2)	V _{ESD}	±20	k V
ESD Protection- Air (Standard IEC 61000-4-2)		±30	
Operating Temperature Range	T _J	-55 to +125	° C
Storage Temperature Range	T _{STG}	-55 to +150	° C
Soldering Temperature, t max =10s	T _L	260	° C

Electrical Characteristics

Parameter	Test Conditions	Symbol	Min	Typ	Max	Unit
Reverse Working Voltage	Any I/O pin to ground	V _{RWM}	-	-	5	V
Reverse Breakdown Voltage	I _T = 1mA Any I/O pin to ground	V _B	6	-	9	V
Reverse Current	V _R = 5V Any I/O pin to ground	I _R	-	-	1	uA
Reverse Clamping Voltage	I _{PP} = 1A (8/20µs) Any I/O pin to ground	V _C	-	-	10	V
	I _{PP} = 4A (8/20µs) Any I/O pin to ground		-	-	15	
Junction Capacitance	V _R = 0V, F = 1MHz Between I/O pins	C _j	-	0.2	0.3	p F
	V _R = 0V, F = 1MHz Any I/O pin to ground		-	0.45	0.6	p F



Rating and Characteristic Curves

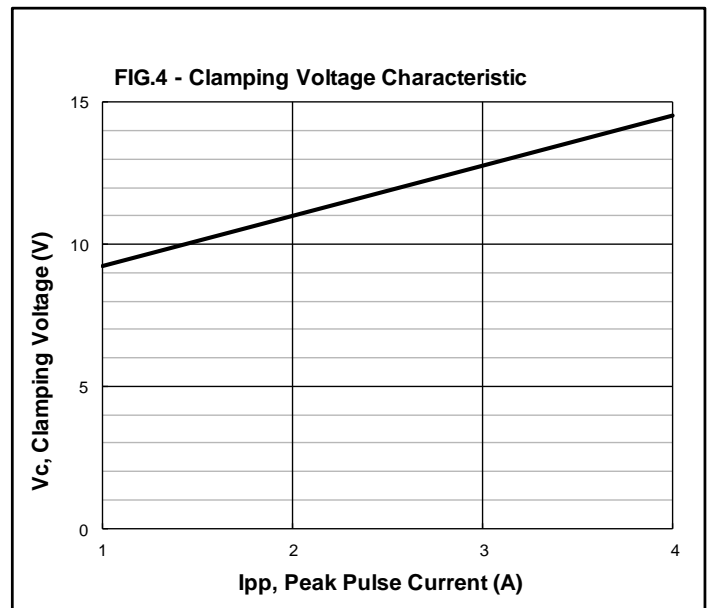
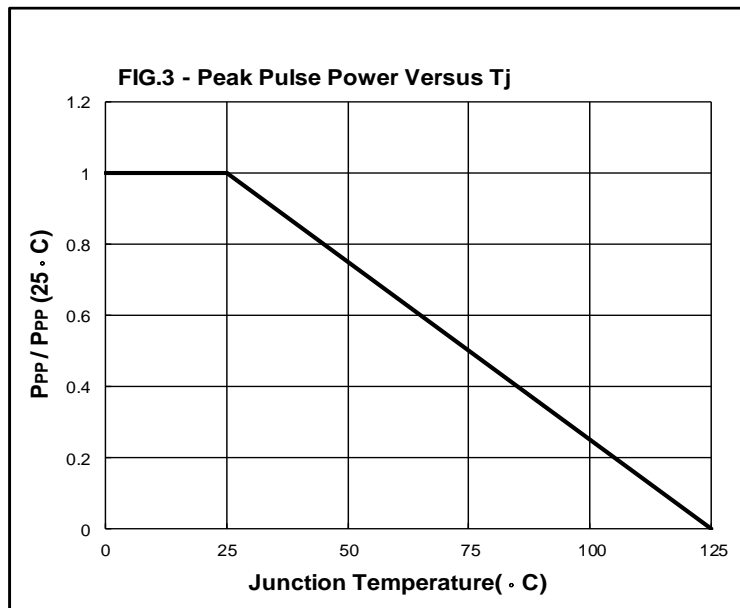
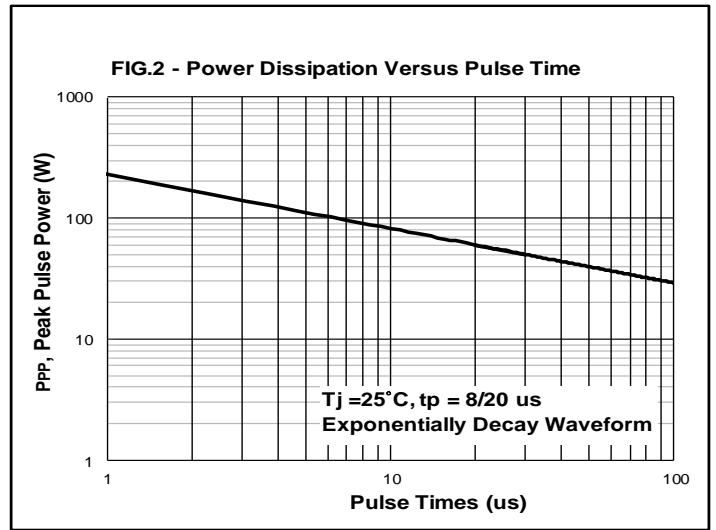
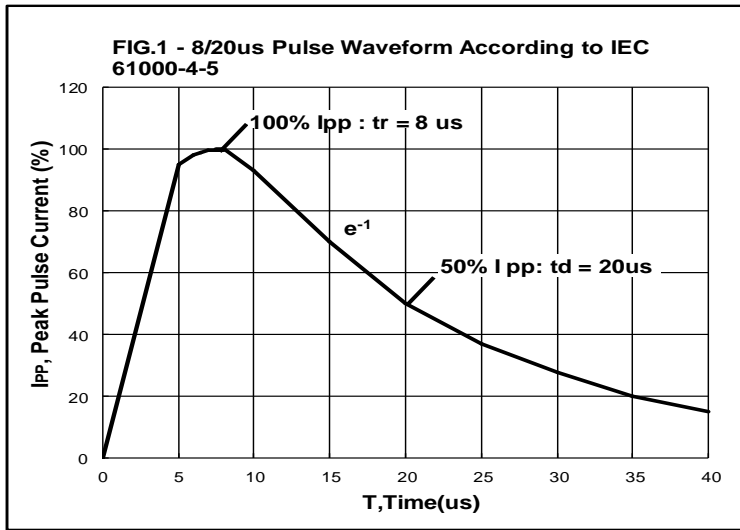



Package Outline Dimensions

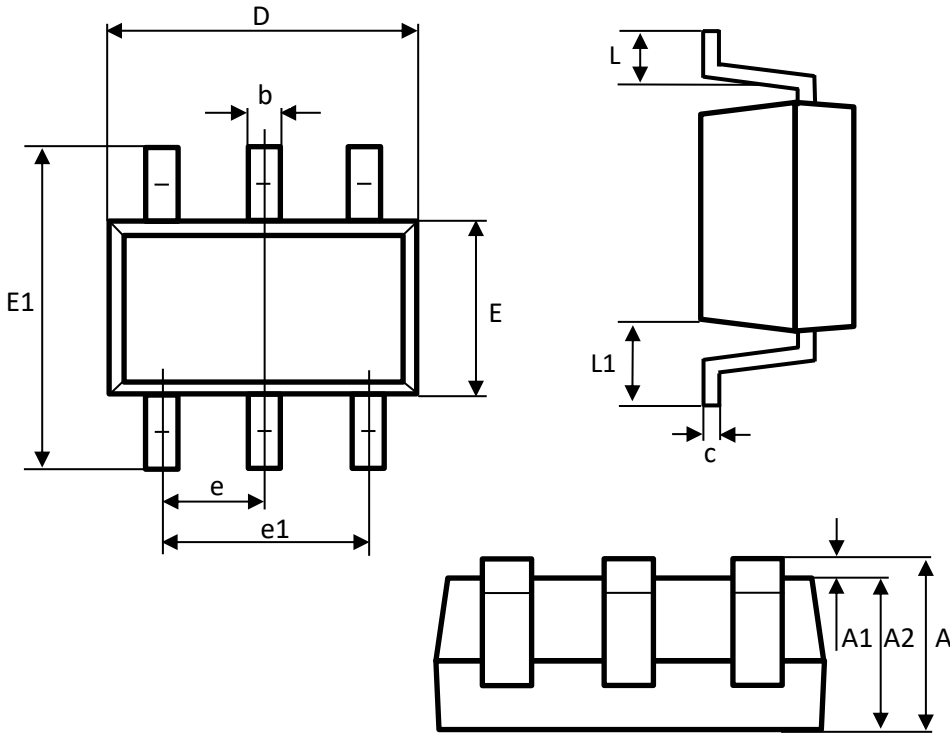

SOT363 Package		
Dim	Min	Max
A	0.90	1.10
A1	0.00	0.10
A2	0.90	1.00
b	0.15	0.35
c	0.08	0.15
D	2.00	2.20
E	1.15	1.35
E1	2.15	2.45
e	0.650 Typ.	
e1	1.20	1.40
L	0.525 Ref.	
L1	0.26	0.46
All Dimensions in mm		

Suggested Soldering Pad Layout

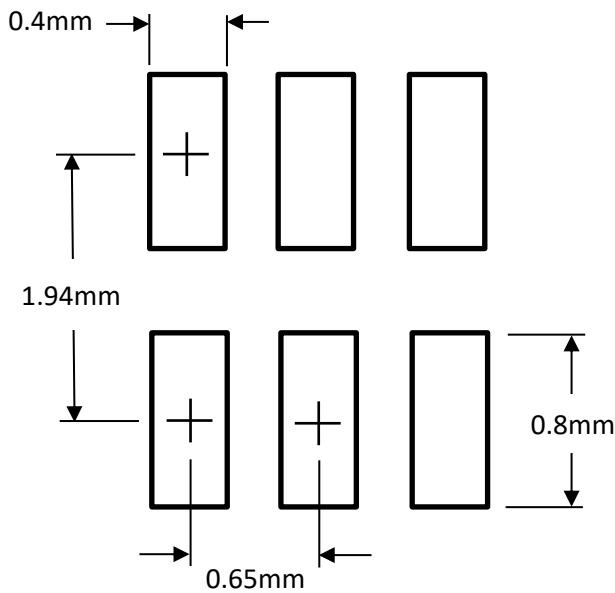



Disclaimer

All specifications and data are subject to be changed without notice to improve reliability function or design or other reasons.

HY makes no warranty, representation or guarantee regarding the suitability of the products for any particular purpose or the continuing production of any product. To the maximum extent permitted by applicable law, HY disclaims (i) any and all liability arising out of the application or use of any product, (ii) any and all liability, including without limitation special, consequential or incidental damages, and (iii) any and all implied warranties, including warranties of fitness for particular purpose, non-infringement and merchantability.

Statements regarding the suitability of products for certain types of applications are based on HY's knowledge of typical requirements that are often placed on HY products in generic applications. Such statements are not binding statements about the suitability of products for a particular application. It is the customer's responsibility to validate that a particular product with the properties described in the product specification is suitable for use in a particular application. Parameters provided in datasheets and specifications may vary in different applications and performance may vary over time. All operating parameters, including typical parameters, must be validated for each customer application by the customer's technical experts. Product specifications do not expand or otherwise modify HY's terms and conditions of purchase, including but not limited to the warranty expressed therein.

Except as expressly indicated in writing, HY products are not designed for use in medical, life-saving, or life-sustaining applications or for any other applications in which the failure of the HY product could result in personal injury or death. Customers using or selling HY products not expressly indicated for use in such applications do so at their own risk. Please contact authorized HY personnel to obtain written terms and conditions regarding products designed for such applications.

No license, express or implied, by estoppel or otherwise, to any intellectual property rights is granted by this document or by any conduct of HY. Product names and markings noted herein may be trademarks of their respective owners.