



N-Channel MOSFET

$V_{DSS}=650V, I_D=4A, R_{DS(ON)}=2.0\Omega(\text{typ})$

Features

- $R_{DS(ON)} = 2\Omega @ V_{GS} = 10V$
- High Input Resistance
- Low On Resistance

Applications

- Electronic Ballasts
- Electronic Transformer
- High Efficiency Switch Mode Power Supplies

Mechanical Data

- Case: ITO-220AB Package
- Case Material: "Green" Molding Compound
UL Flammability Classification Rating 94V-0
- Halogen Free

Ordering Information

- Package: ITO-220AB
- Quantity Per Tube: 50 pcs

Package Outline

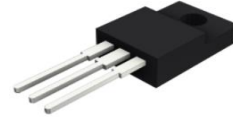

ITO-220AB Top View

Marking Information

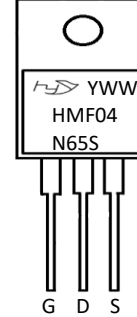

Device Schematic

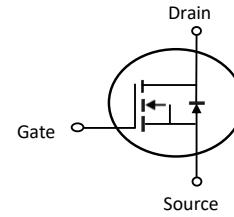

Maximum Ratings (@TA = +25°C, unless otherwise specified.)

Parameter	Symbol	Value	Unit
Drain-Source Voltage	V_{DSS}	650	V
Gate-Source Voltage	V_{GSS}	± 30	V
Avalanche Current (Note 2.)	I_{AR}	4	A
Continuous Drain Current	I_D	4	A
Pulsed Drain Current (Note 2.)	I_{DM}	16	A
Single Pulsed Avalanche Energy (Note 3.)	E_{AS}	260	mJ
Repetitive Avalanche Energy (Note 2.)	E_{AR}	10.6	mJ
Peak Diode Recovery dv/dt (Note 4.)	dv/dt	4.5	V/ns
Power Dissipation	P_D	36	W
Junction Temperature	T_j	150	°C
Operating Temperature Range	T_{OPR}	-55 to +150	°C
Storage Temperature Range	T_{STG}	-55 to +150	°C

Notes: 1. Absolute maximum ratings are those values beyond which the device could be permanently damaged.

Absolute maximum ratings are stress ratings only and functional device operation is not implied.

2. Repetitive Rating : Pulse width limited by maximum junction temperature

3. $L = 30mH, I_{AS} = 4A, V_{DD} = 50V, R_G = 25\Omega, \text{Starting } T_J = 25^\circ C$

4. $I_{SD} \leq 4.4A, di/dt \leq 200A/\mu s, V_{DD} \leq BV_{DSS}, \text{Starting } T_J = 25^\circ C$



Electrical Characteristics(@TA = +25°C, unless otherwise specified.)

Parameter	Test Conditions	Symbol	Min	Typ	Max	Unit
OFF Characteristics						
Drain-Source Breakdown Voltage	$V_{GS}=0V, I_D=250\mu A$	BV_{DSS}	650	-	-	V
Forward Gate-Source Leakage Current	$V_{DS}=0V, V_{GS}=30V$	I_{GSS}	-	-	100	nA
Reverse Gate-Source Leakage Current	$V_{DS}=0V, V_{GS}=-30V$		-	-	-100	nA
Drain-Source Leakage Current	$V_{DS}=650V, V_{GS}=0V$	I_{DSS}	-	-	10	μA
ON Characteristics						
Gate-Threshold Voltage	$V_{DS}=V_{GS}, I_D=250\mu A$	$V_{th(GS)}$	2	-	4	V
Static Drain-Source On-State Resistance	$V_{GS}=10V, I_D=2A$	$R_{DS(ON)}$	-	2	2.4	Ω
Dynamic Characteristics						
Input Capacitance	$V_{DS}=25V, V_{GS}=0V, F=1MHz$	C_{ISS}	-	520	670	pF
Output Capacitance		C_{OSS}	-	70	90	
Reverse Transfer Capacitance		C_{RSS}	-	8	11	
Switching Characteristics						
Turn-On Delay Time	$V_{DD}=325V, I_D=4.0A,$ $R_G=25\Omega$ (Note 1,2)	$t_{D(ON)}$	-	13	35	ns
Turn-On Rise Time		t_R	-	45	100	
Turn-Off Delay Time		$t_{D(OFF)}$	-	25	60	
Turn-Off Fall Time		t_F	-	35	80	
Switching Characteristics						
Total Gate Charge	$V_{DS}=520V, V_{GS}=10V,$ $I_D=4A,$ (Note 1,2)	Q_G	-	15	20	nC
Gate-Source Charge		Q_{GS}	-	3.4	-	
Gate-Drain Charge		Q_{GD}	-	7.1	-	
Drain-Source Diode Characteristics And Maximum Ratings						
Drain-Source Diode Forward Voltage	$I_S=4A, V_{GS}=0V$	V_{SD}	-	-	1.4	V
Continuous Drain-Source Diode Forward Current	-	I_S	-	-	4.4	A
Pulsed Drain-Source Diode Forward Current	-	I_{SM}	-	-	17.6	A
Reverse Recovery Time	$V_{GS}=0V, I_S=4A,$ $dI_F/dt=100A/\mu s$ (Note 1)	t_{RR}	-	250	-	ns
Reverse Recovery Charge		Q_{RR}	-	1.5	-	μC

Notes: 1. Pulse Test : Pulse width $\leq 300\mu s$, Duty cycle $\leq 2\%$

2. Essentially independent of operating temperature



Rating and Characteristic Curves

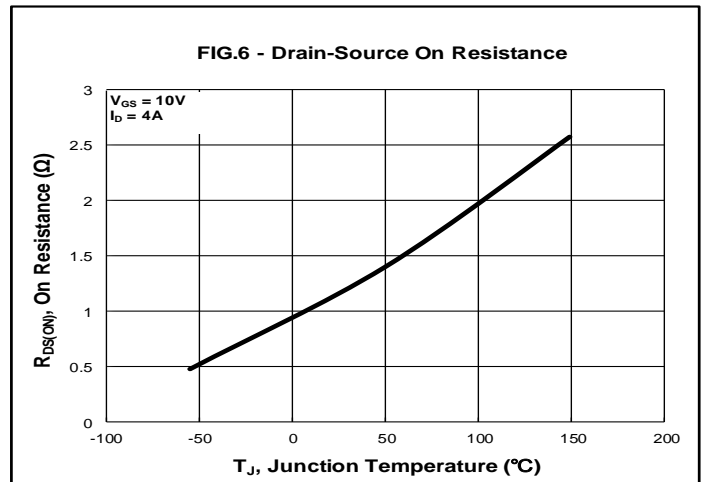
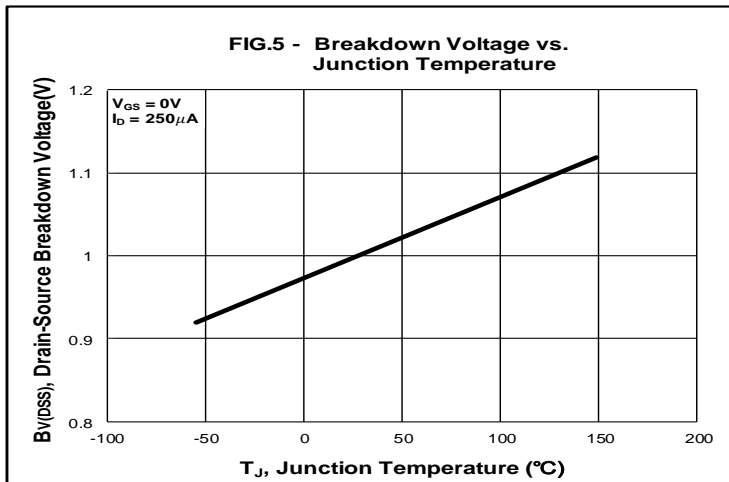
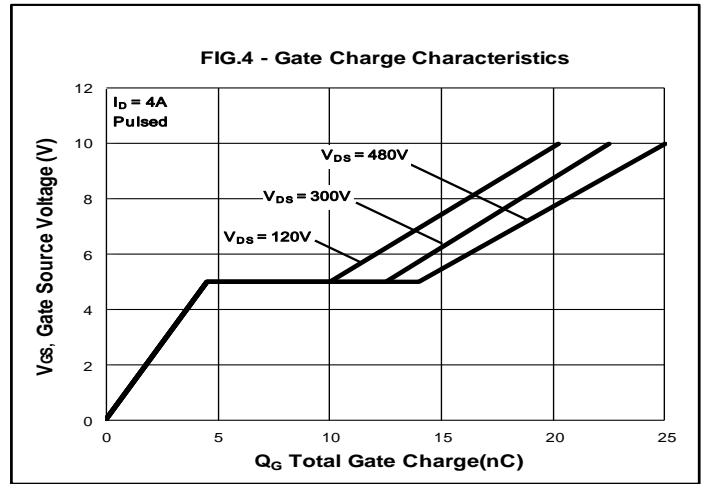
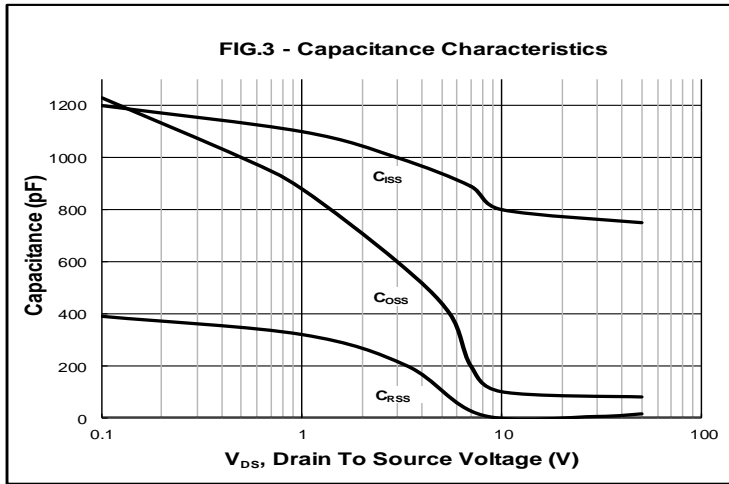
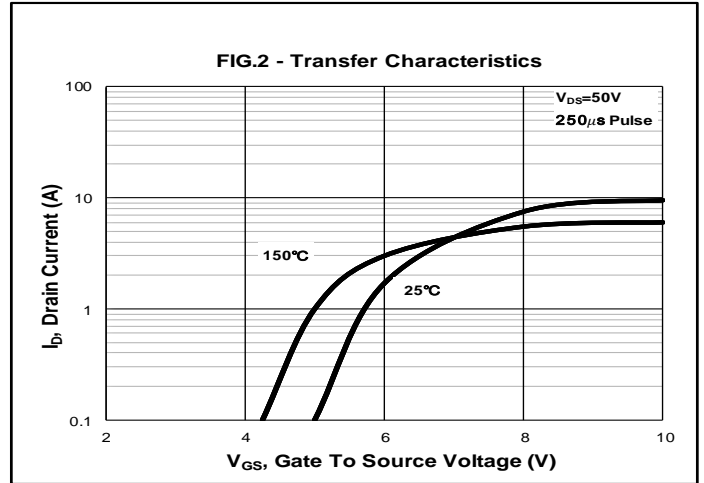
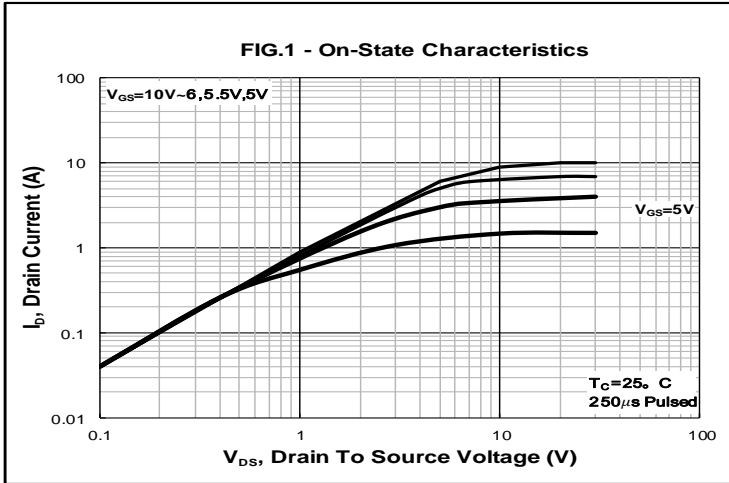



Rating and Characteristic Curves

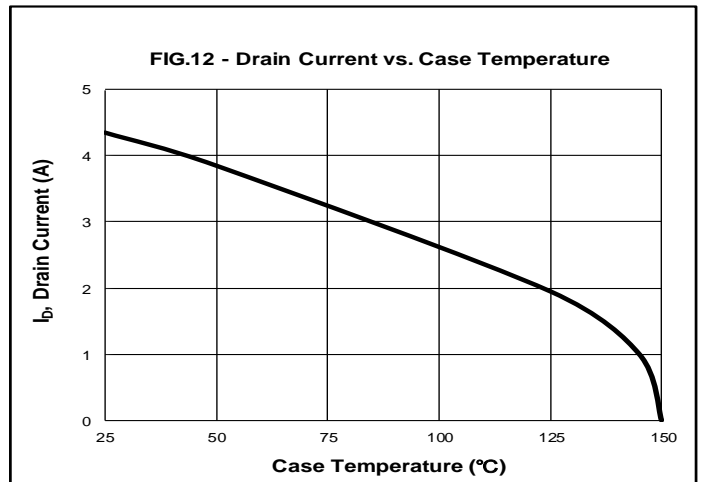
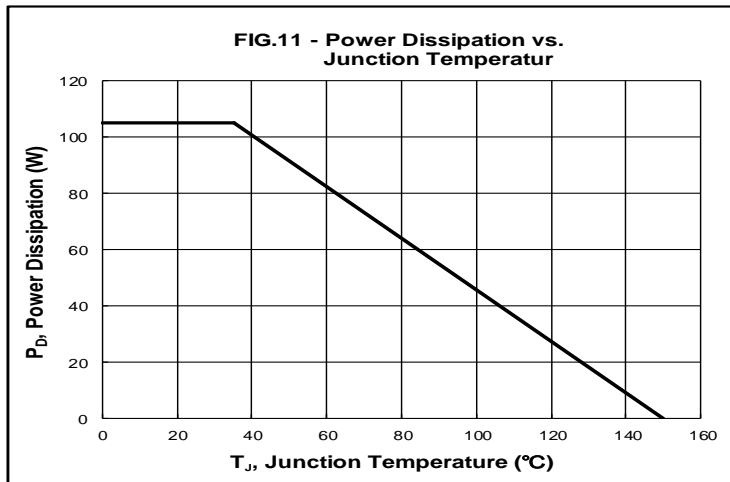
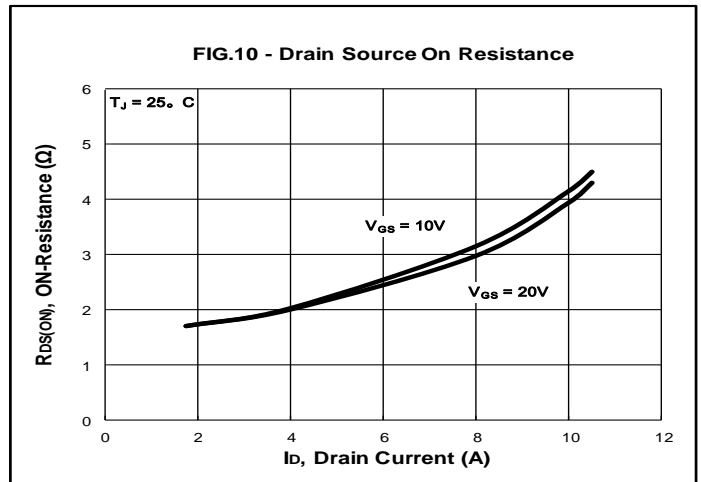
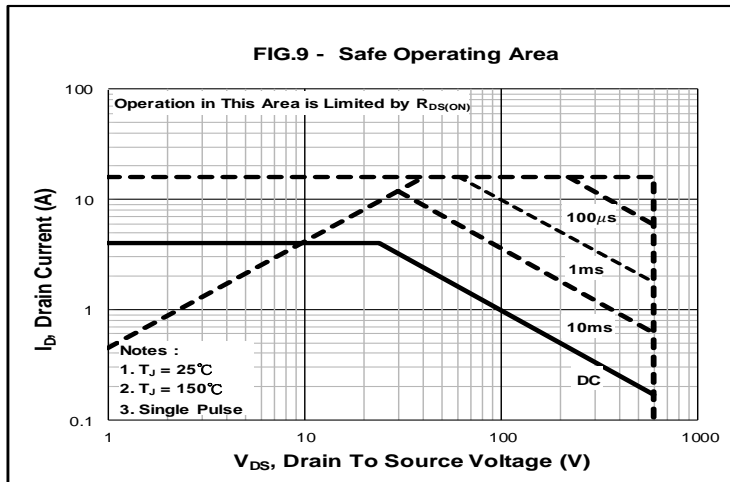
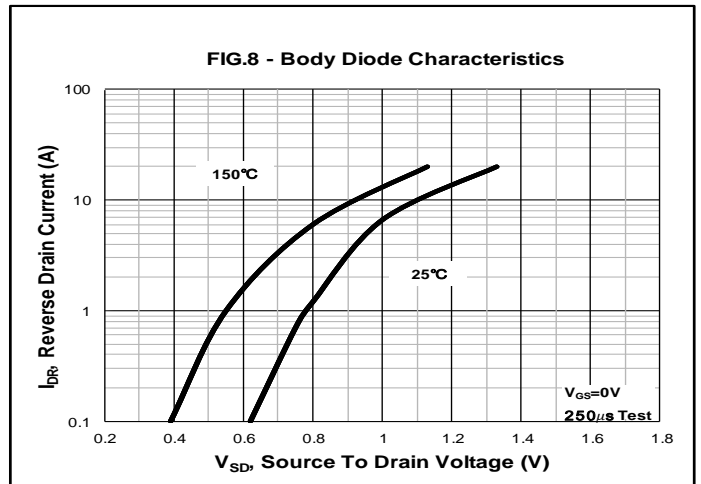
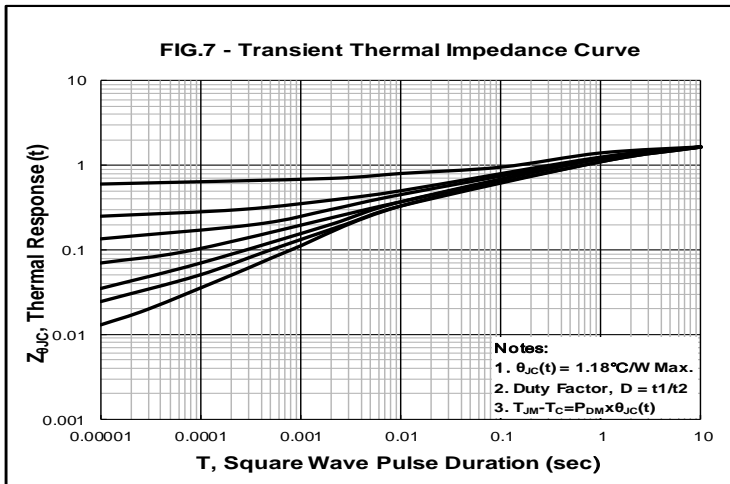



Package Outline Dimensions

ITO-220AB

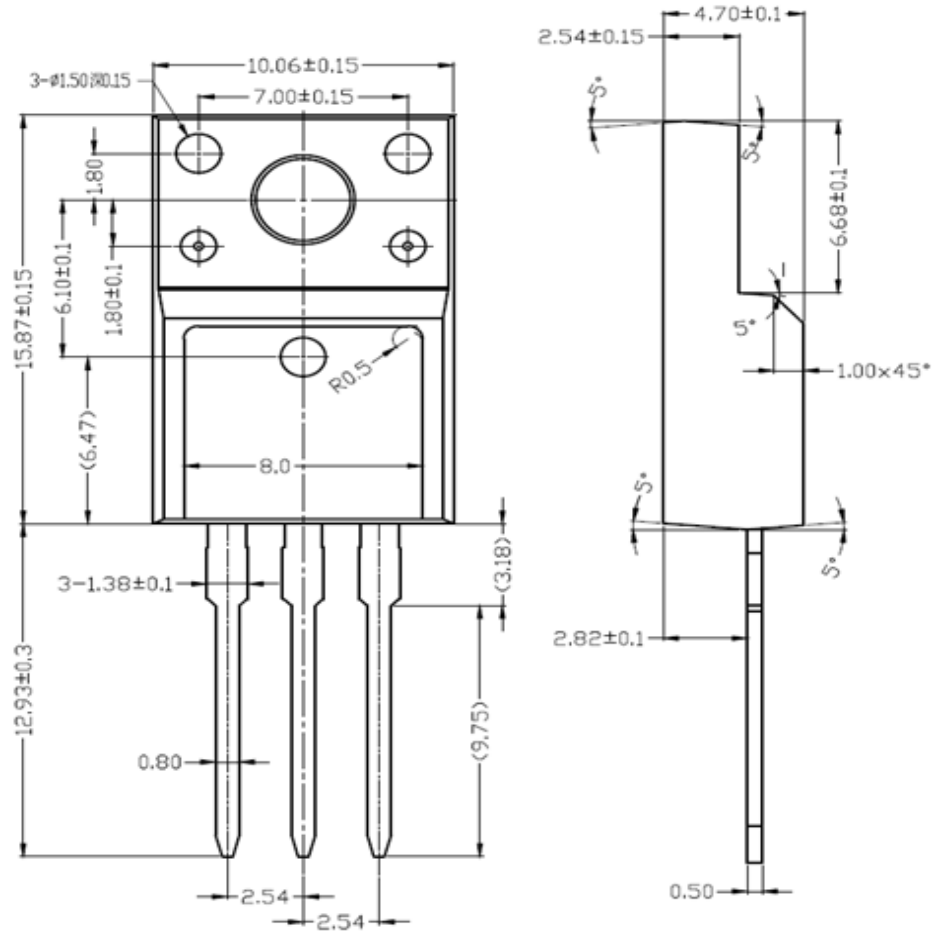



Disclaimer

All specifications and data are subject to be changed without notice to improve reliability function or design or other reasons.

HY makes no warranty, representation or guarantee regarding the suitability of the products for any particular purpose or the continuing production of any product. To the maximum extent permitted by applicable law, HY disclaims (i) any and all liability arising out of the application or use of any product, (ii) any and all liability, including without limitation special, consequential or incidental damages, and (iii) any and all implied warranties, including warranties of fitness for particular purpose, non-infringement and merchantability.

Statements regarding the suitability of products for certain types of applications are based on HY's knowledge of typical requirements that are often placed on HY products in generic applications. Such statements are not binding statements about the suitability of products for a particular application. It is the customer's responsibility to validate that a particular product with the properties described in the product specification is suitable for use in a particular application. Parameters provided in datasheets and specifications may vary in different applications and performance may vary over time. All operating parameters, including typical parameters, must be validated for each customer application by the customer's technical experts. Product specifications do not expand or otherwise modify HY's terms and conditions of purchase, including but not limited to the warranty expressed therein.

Except as expressly indicated in writing, HY products are not designed for use in medical, life-saving, or life-sustaining applications or for any other applications in which the failure of the HY product could result in personal injury or death. Customers using or selling HY products not expressly indicated for use in such applications do so at their own risk. Please contact authorized HY personnel to obtain written terms and conditions regarding products designed for such applications.

No license, express or implied, by estoppel or otherwise, to any intellectual property rights is granted by this document or by any conduct of HY. Product names and markings noted herein may be trademarks of their respective owners.