



KBL6005G thru KBL610G

GLASS PASSIVATED BRIDGE RECTIFIERS

REVERSE VOLTAGE - 50 to 1000Volts
FORWARD CURRENT - 6.0Amperes

FEATURES

- Surge overload rating -150 Amperes peak
- Ideal for printed circuit board
- Plastic material has UL flammability classification 94V-0
- Mounting position :Any

Note: Products with logo  or  are made by HY Electronic (Cayman) Limited.

KBL

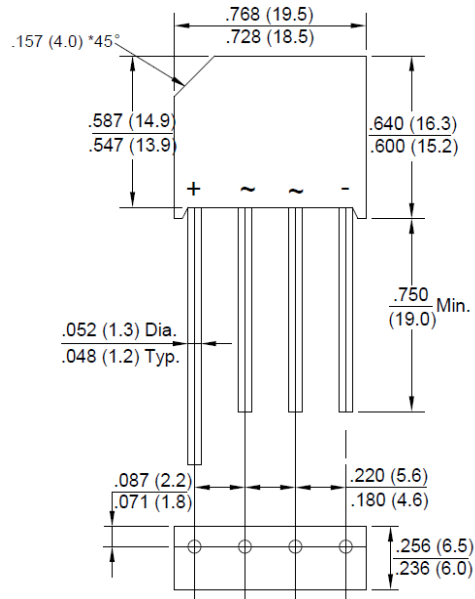

RoHS
COMPLIANT

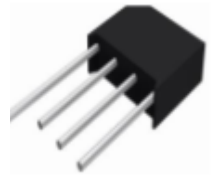

Dimensions in inches and (millimeters)

MAXIMUM RATINGS AND ELECTRICAL CHARACTERISTICS

Rating at 25°C ambient temperature unless otherwise specified.

Single phase, half wave ,60Hz, resistive or inductive load.

For capacitive load, derate current by 20%

CHARACTERISTICS	SYMBOL	KBL	KBL	KBL	KBL	KBL	KBL	KBL	UNIT
		6005G	601G	602G	604G	606G	608G	610G	
Maximum Recurrent Peak Reverse Voltage	VRRM	50	100	200	400	600	800	1000	V
Maximum RMS Bridge Input Voltage	VRMS	35	70	140	280	420	560	700	V
Maximum DC Blocking Voltage	VDC	50	100	200	400	600	800	1000	V
Maximum Average Forward Output Current at 50°C TA (Note1)	I(AV)	6.0							A
Peak Forward Surge Current 8.3ms Single Half Sine-Wave Super Imposed on Rated Load	IFSM	125							A
I ² t Rating for Fusing (t<8.3mS)	I ² t	64.8							A ² s
Maximum Forward Voltage Drop Per Element at 3.0A Peak	VF	1.1							V
Maximum DC Reverse Current at Rated DC Blocking Voltage	IR	10.0							µA
Maximum Reverse Current at Rated DC Blocking Voltage and 150°C TA	IR	1.0							mA
Operating Temperature Range	TJ	-55 to +150							°C
Storage Temperature Range	TSTG	-55 to +150							°C

NOTES : 1. Mounting conditions ,0.5" lead length maximum.

KBL6*G-B-(N)00-00

Rev.2, 31-Aug-2020



FIG.1-MAXIMUM FORWARD SURGE CURRENT

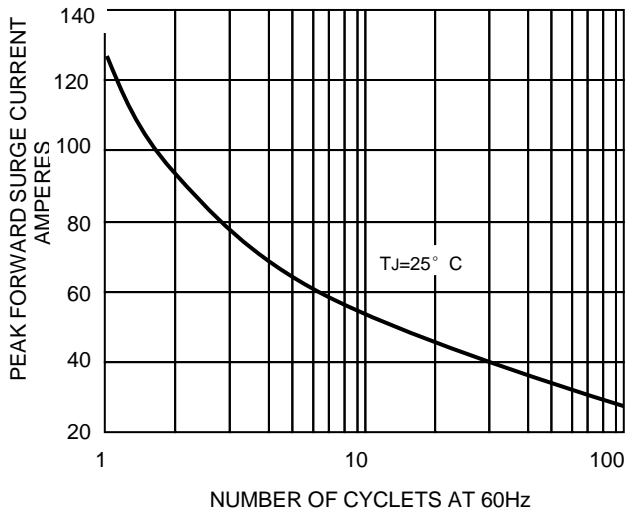

FIG.1-DERATING CURVE
 OUTPUT RECTIFIED CURRENT

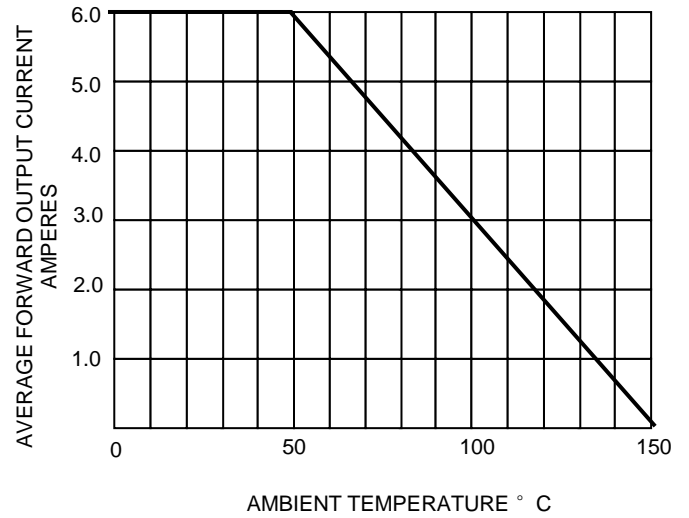

FIG.4-TYPICAL FORWARD CHARACTERISTICS

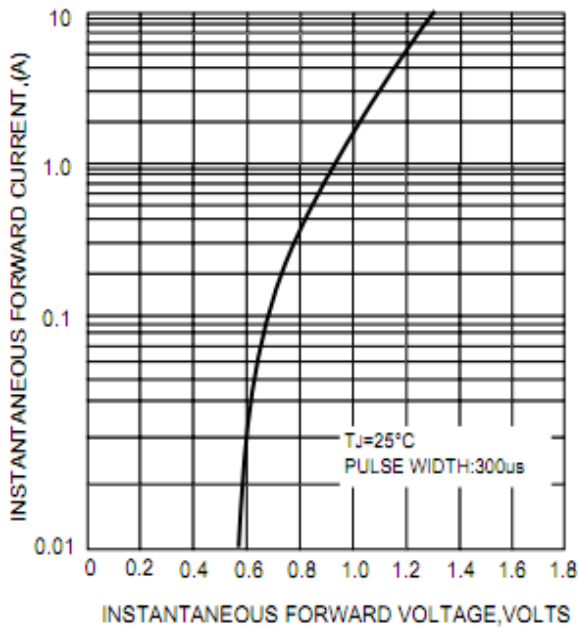
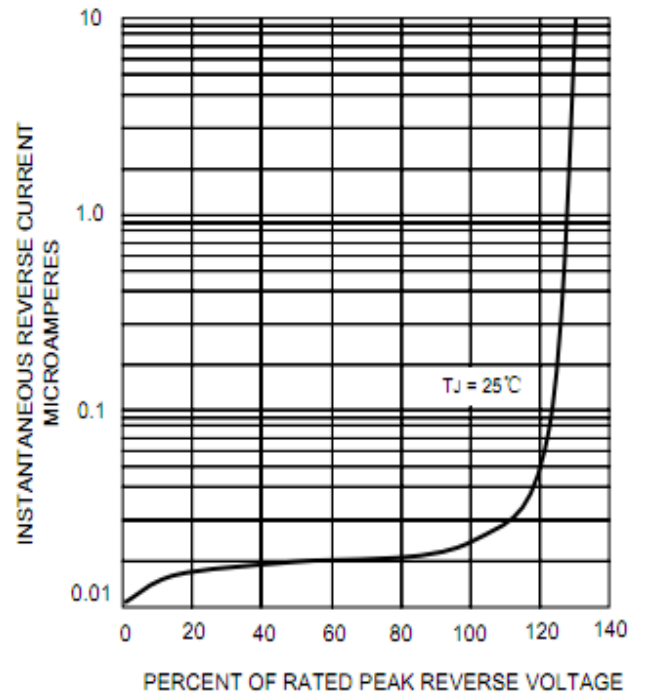

FIG.4- TYPICAL REVERSE CHARACTERISTICS



The curve graph is for reference only.



Disclaimer

ALL specifications and data are subject to be changed without notice to improve reliability function or design or other reasons.

HY makes no warranty, representation or guarantee regarding the suitability of the products for any particular purpose or the continuing production of any product. To the maximum extent permitted by applicable law, HY disclaims (i) any and all liability arising out of the application or use of any product, (ii) any and all liability, including without limitation special, consequential or incidental damages, and (iii) any and all implied warranties, including warranties of fitness for particular purpose, non-infringement and merchantability.

Statements regarding the suitability of products for certain types of applications are based on HY's knowledge of typical requirements that are often placed on HY products in generic applications. Such statements are not binding statements about the suitability of products for a particular application. It is the customer's responsibility to validate that a particular product with the properties described in the product specification is suitable for use in a particular application. Parameters provided in datasheets and specifications may vary in different applications and performance may vary over time. All operating parameters, including typical parameters, must be validated for each customer application by the customer's technical experts. Product specifications do not expand or otherwise modify HY's terms and conditions of purchase, including but not limited to the warranty expressed therein.

Except as expressly indicated in writing, HY products are not designed for use in medical, life-saving, or life-sustaining applications or for any other applications in which the failure of the HY product could result in personal injury or death. Customers using or selling HY products not expressly indicated for use in such applications do so at their own risk. Please contact authorized HY personnel to obtain written terms and conditions regarding products designed for such applications.

No license, express or implied, by estoppel or otherwise, to any intellectual property rights is granted by this document or by any conduct of HY. Product names and markings noted herein may be trademarks of their respective owners.